



US 20100295828A1

(19) **United States**

(12) **Patent Application Publication**
SUNG et al.

(10) **Pub. No.: US 2010/0295828 A1**

(43) **Pub. Date: Nov. 25, 2010**

(54) **ORGANIC LIGHT EMITTING DIODE DISPLAY**

(30) **Foreign Application Priority Data**

Nov. 18, 2005 (KR) 10-2005-0110712

(75) Inventors: **Un-Cheol SUNG**, Anyang-si (KR);
Joo-Hyeon LEE, Yongin-si (KR)

Publication Classification

Correspondence Address:
CANTOR COLBURN LLP
20 Church Street, 22nd Floor
Hartford, CT 06103 (US)

(51) **Int. Cl.**
G09G 3/32 (2006.01)
G09G 5/00 (2006.01)
H01L 51/52 (2006.01)

(52) **U.S. Cl. 345/204; 257/98; 345/76; 257/E51.022**

(73) Assignee: **SAMSUNG ELECTRONICS CO., LTD**, Suwon-si (KR)

(57) **ABSTRACT**

(21) Appl. No.: **12/848,465**

An OLED display for improving white light emitting efficiency and simplifying a manufacturing process includes a plurality of pixels, each of the pixels having a transistor unit, a color filter unit and an organic light emitting device unit. The transistor unit converts signals from the outside into driving signals for driving an organic light emitting device unit. The organic light emitting device unit is composed of blue, red and green emission layers each having different areas. By passing white light through a color filter, the OLED display can realize full color.

(22) Filed: **Aug. 2, 2010**

Related U.S. Application Data

(62) Division of application No. 11/535,589, filed on Sep. 27, 2006, now Pat. No. 7,789,724.

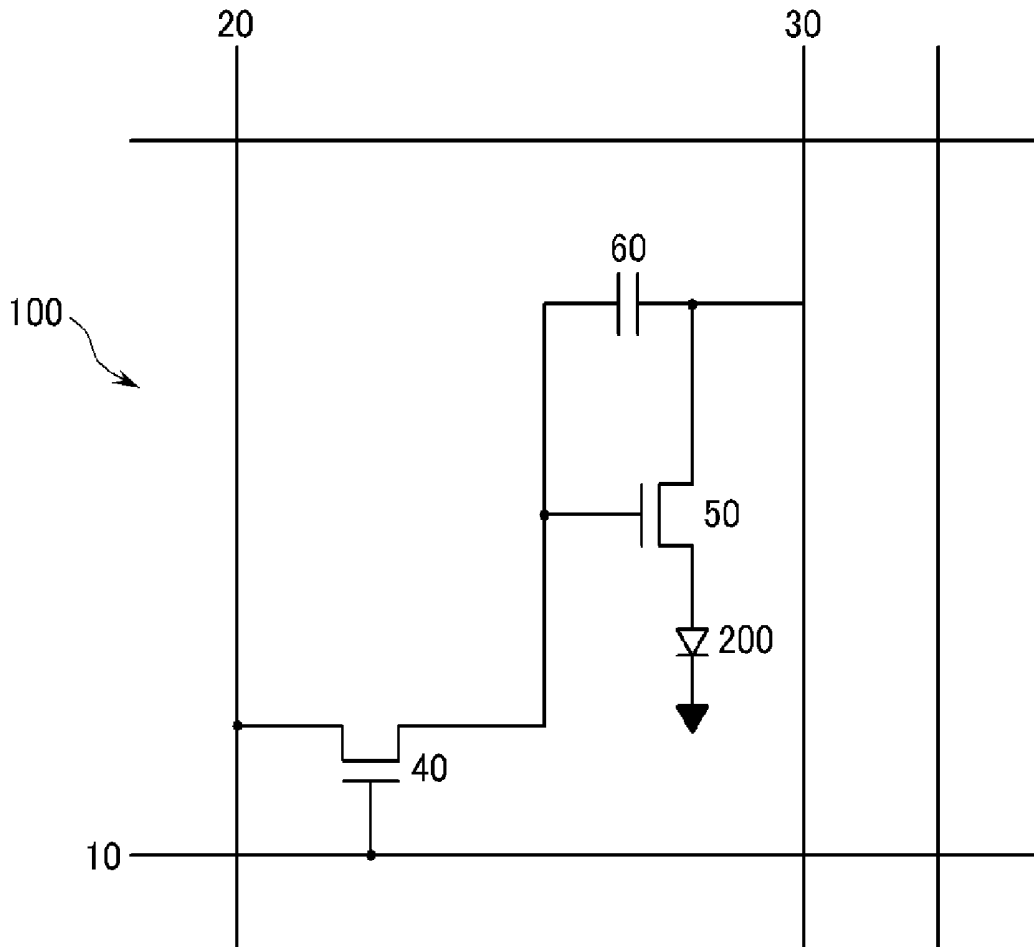

FIG. 1

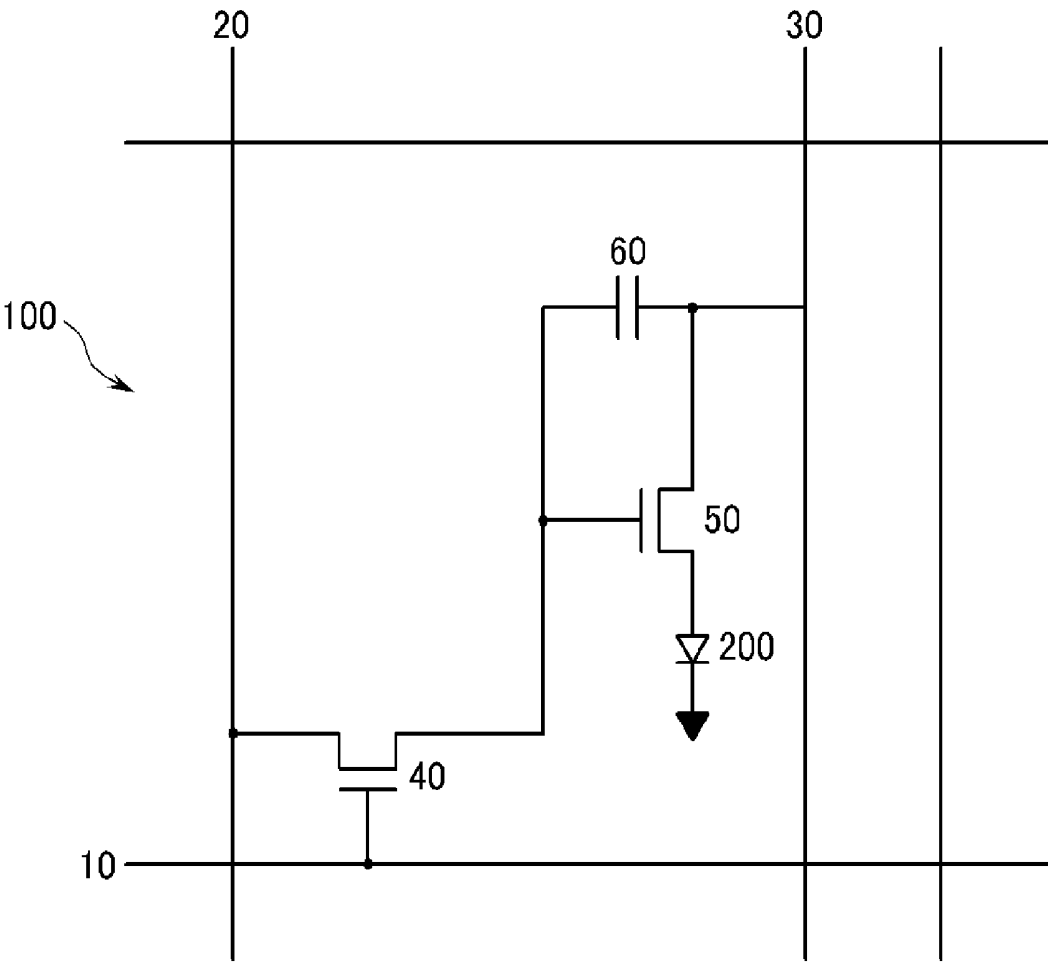

FIG. 2

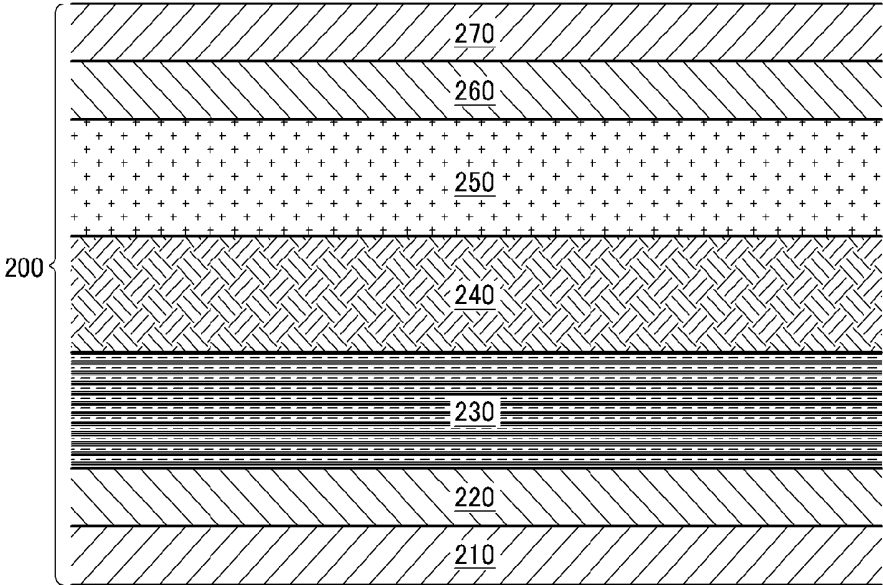

FIG. 3

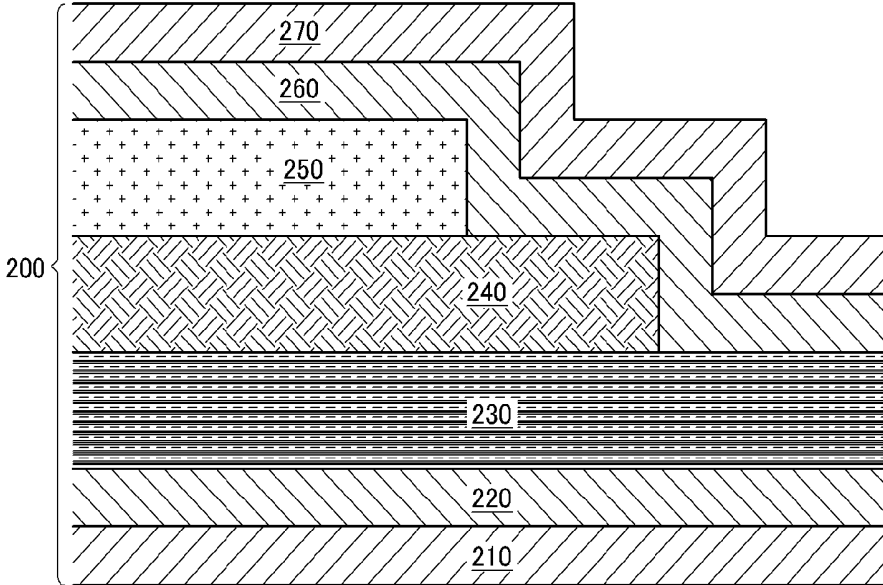

FIG. 4

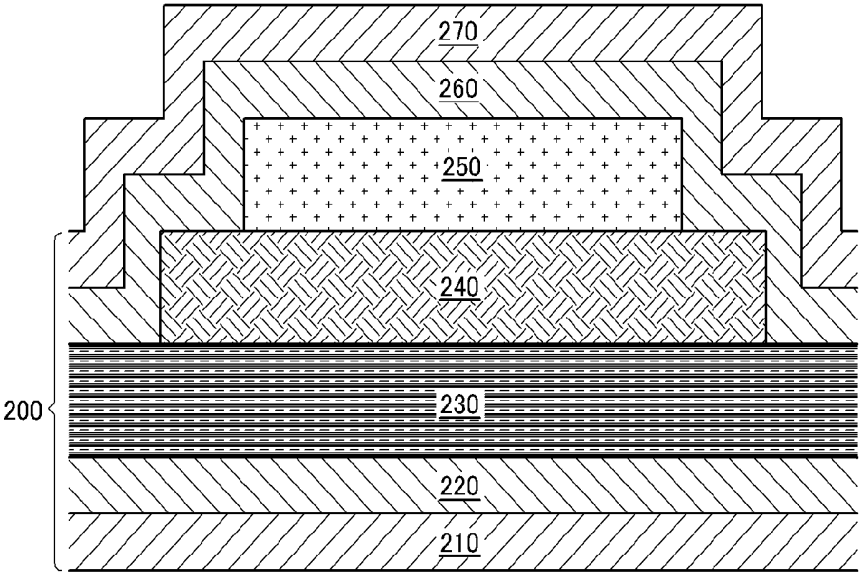

FIG. 5

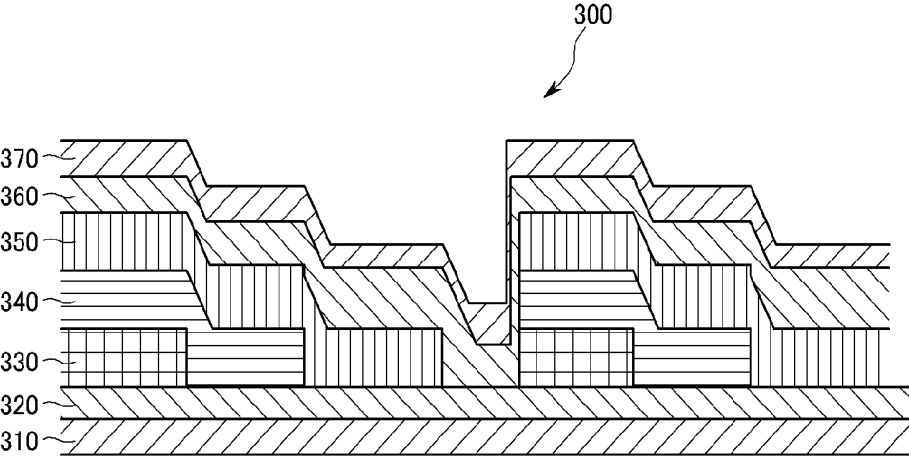

FIG. 6

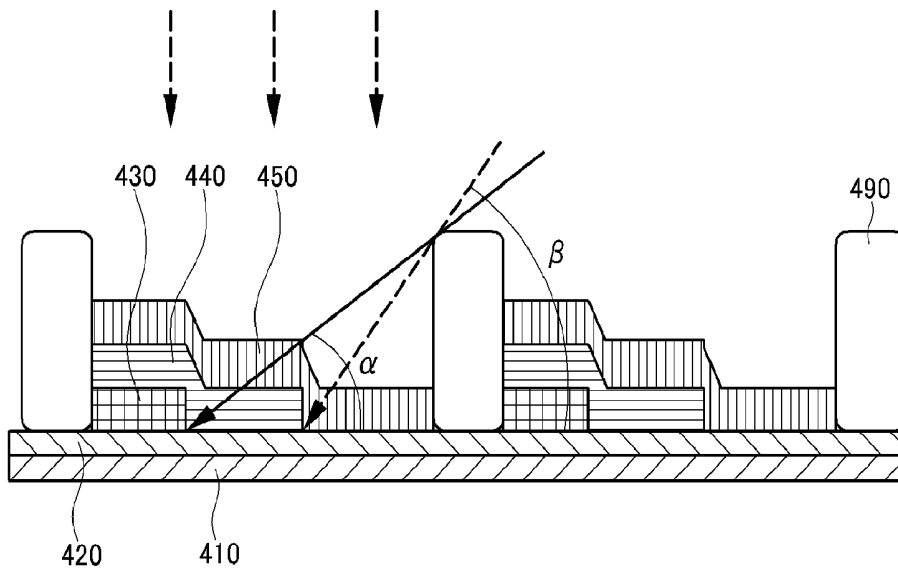
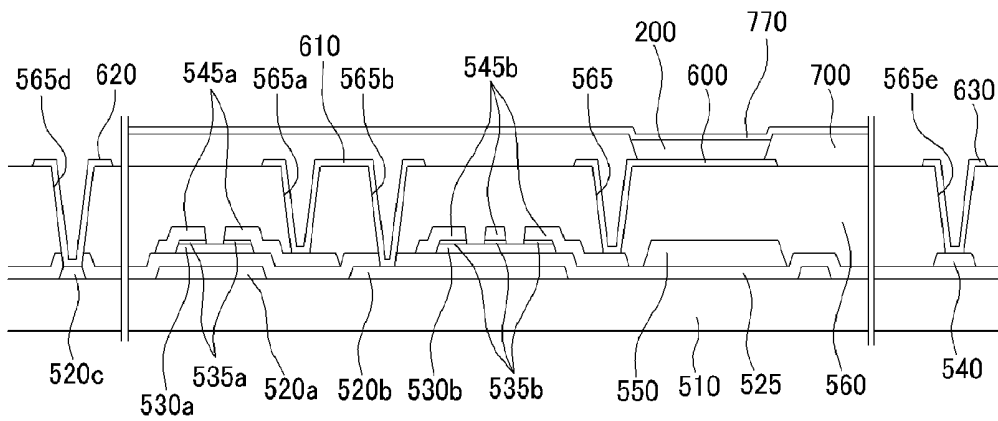

FIG. 7



ORGANIC LIGHT EMITTING DIODE DISPLAY

[0001] This application is a divisional of U.S. application Ser. No. 11/535,589, filed on Sep. 27, 2006, which claims priority to Korean Patent Application No. 10-2005-0110712, filed on Nov. 18, 2005, and all the benefits accruing therefrom under 35 U.S.C. §119, the contents of which in its entirety are herein incorporated by reference.

BACKGROUND OF THE INVENTION

[0002] (a) Field of the Invention

[0003] The present invention relates to an organic light emitting diode ("OLED") display. More particularly, the present invention provides an OLED display and a method of manufacturing the same for improving white light emitting efficiency and simplifying a manufacturing process thereof.

[0004] (b) Description of the Related Art

[0005] Display devices using a cathode ray tube have been widely used. However, display devices using cathode ray tubes have drawbacks that the volume and weight thereof are large and heavy, respectively, and that they are not easily portable. Recently, in order to overcome the drawbacks of display devices using cathode ray tubes, liquid crystal displays and plasma display devices have been developed and used. Use of liquid crystal displays and plasma display devices have provided rapid progress in space saving and portability.

[0006] A liquid crystal display is a non-emissive device that includes a light source for emitting white light and a liquid crystal display unit for controlling the transmittance of the light emitted from the light source. The response speed of a liquid crystal display is only as fast as the time that it takes for a twisted nematic crystal to twist or untwist. Therefore, the liquid crystal display has drawbacks such as high power consumption and slow response speed. A plasma display device also has drawbacks such as high power consumption, driving complexity and low resolution. The inherent drawbacks of the plasma display come from the size of the plasma cells necessary to make an individual pixel and the nature of the injected ionizing gas which must be driven therein. In order to overcome the drawbacks of the liquid crystal display and the plasma display device, much research regarding an organic light emitting diode ("OLED") display has been undertaken. The OLED display is itself a light-emitting device, and it may contain a plurality of light-emitting devices arranged on a substrate in a matrix and an additional substrate for protecting the substrate with the light-emitting devices. The OLED display has characteristics of low power consumption, high response speed, wide viewing angle and high resolution.

[0007] The OLED display operates on the principle that organic emission layers, which are placed between an anode providing holes and a cathode providing electrons, generate excitons by hole-electron coupling. The excitons emit light because of the energy released by the coupling (otherwise known as de-excitation). In order to display full color images, the OLED display includes a pixel array for emitting red, green and blue colors. However, the emission efficiency and lifetime of the different organic emission layers used to make red, green and blue pixels differ from each other. Therefore, various remedies have been introduced. In order to solve the described problems of the OLED, U.S. Pat. No. 6,366,025 discloses a technique for forming red, green and blue pixels

each having different areas. However, the OLED display having different sized pixels has difficulties in design and driving, such as a low response time.

[0008] The OLED display may realize full color by overlapping red, green and blue emission layers having the same areas in one pixel, and disposing a color filter on the emission layers. Such a structure is disclosed in U.S. Pat. No. 6,392,340. In this case, the overlapping emission layers have the same areas and in combination emit white light. The white light is then passed through a color filter to obtain red, green and blue light. In the OLED disclosed in U.S. Pat. No. 6,392,340, the lifetime and characteristics of the emission layers also differ from each other. Also, it has difficulties in that its high luminance white light emitting lifespan is reduced because of a strong interaction between the different emission layers.

BRIEF SUMMARY OF THE INVENTION

[0009] Accordingly, one aspect of the present invention is to provide an OLED display and a method for manufacturing the same for minimizing interference between organic emission layers.

[0010] An exemplary embodiment of an OLED display according to the present invention includes; an anode which provides holes; a cathode which provides electrons, a plurality of organic emission layers disposed between the anode and the cathode, the plurality of organic emission layers emit light each having different wavelengths through coupling of the holes from the anode and the electrons from the cathode, and a color filter layer which passes the light emitted from the plurality of organic emission layers, wherein the plurality of organic emission layers are sequentially stacked and each have a different surface area.

[0011] An exemplary embodiment of the OLED display according to the present invention includes; a gate electrode which provides gate signals, a data electrode which provides data signals, a power source electrode which provides power source signals, a switching transistor and a driving transistor operated in response to signals provided from the gate electrode, the data electrode, and the power source electrode, an anode electrically connected to the driving transistor which provides holes, a cathode disposed opposite the anode which provides electrons, first, second and third emission layers disposed between the anode and the cathode to be overlapped with each other, and a color filter overlapped with the first, second and third emission layers, wherein the first, second and third emission layers each have different emission surface areas.

[0012] An exemplary embodiment of a method of manufacturing an organic light emitting diode display includes; providing a substrate including a gate electrode, a data electrode, a power source electrode and a color filter, forming an anode on the substrate, applying a photoresist on the substrate, forming a protrusion around an emission region by exposing and developing the photoresist to expose at least a part of the photoresist around the emission region, forming a first emission layer by applying a first light emitting material at a first angle to a substrate surface, forming a second emission layer on the first emission layer by applying a second light emitting material at a second angle to the substrate surface, wherein the second angle differs from the first angle, and forming a cathode on the first and second emission layers.

[0013] An exemplary embodiment of a method of manufacturing an organic light emitting diode display includes;

providing a gate electrode, a data electrode, a power source electrode and a color filter on a substrate, forming an anode which provides holes on the substrate, forming a protrusion around an emission region by screen printing, forming a first emission layer by applying a first light emitting material at a first angle to the substrate surface, forming a second emission layer on the first emission layer by applying a second light emitting material at a second angle to the surface of the substrate, wherein the second angle differs from the first angle, and forming a cathode on the first and second emission layers which provides electrons.

BRIEF DESCRIPTION OF THE DRAWINGS

[0014] FIG. 1 is an equivalent circuit diagram of an exemplary embodiment of an OLED display according to the present invention;

[0015] FIGS. 2, 3, 4 and 5 are cross-sectional views showing the areas of differing emission layers in exemplary embodiments of an OLED display according to the present invention;

[0016] FIG. 6 is a view illustrating an exemplary embodiment of a process of forming emission layers each having different areas in an exemplary embodiment of an OLED display according to the present invention; and

[0017] FIG. 7 is a cross-sectional view of one pixel in an exemplary embodiment of an OLED display according to the present invention.

DETAILED DESCRIPTION OF THE INVENTION

[0018] The present invention now will be described more fully hereinafter with reference to the accompanying drawings, in which exemplary embodiments of the present invention are shown. This invention may, however, be embodied in many different forms and should not be construed as limited to the embodiments set forth herein. Rather, these embodiments are provided so that this disclosure will be thorough and complete, and will fully convey the scope of the invention to those skilled in the art. Like reference numerals refer to like elements throughout.

[0019] It will be understood that when an element is referred to as being "on" another element, it can be directly on the other element or intervening elements may be present therebetween. In contrast, when an element is referred to as being "directly on" another element, there are no intervening elements present. As used herein, the term "and/or" includes any and all combinations of one or more of the associated listed items.

[0020] It will be understood that, although the terms first, second, third etc. may be used herein to describe various elements, components, regions, layers and/or sections, these elements, components, regions, layers and/or sections should not be limited by these terms. These terms are only used to distinguish one element, component, region, layer or section from another region, layer or section. Thus, a first element, component, region, layer or section discussed below could be termed a second element, component, region, layer or section without departing from the teachings of the present invention.

[0021] The terminology used herein is for the purpose of describing particular embodiments only and is not intended to be limiting of the invention. As used herein, the singular forms "a", "an" and "the" are intended to include the plural forms as well, unless the context clearly indicates otherwise. It will be further understood that the terms "comprises" and/

or "comprising," or "includes" and/or "including" when used in this specification, specify the presence of stated features, regions, integers, steps, operations, elements, and/or components, but do not preclude the presence or addition of one or more other features, regions, integers, steps, operations, elements, components, and/or groups thereof.

[0022] Furthermore, relative terms, such as "lower" or "bottom" and "upper" or "top," may be used herein to describe one element's relationship to another elements as illustrated in the Figures. It will be understood that relative terms are intended to encompass different orientations of the device in addition to the orientation depicted in the Figures. For example, if the device in one of the figures is turned over, elements described as being on the "lower" side of other elements would then be oriented on "upper" sides of the other elements. The exemplary term "lower", can therefore, encompass both an orientation of "lower" and "upper," depending of the particular orientation of the figure. Similarly, if the device in one of the figures is turned over, elements described as "below" or "beneath" other elements would then be oriented "above" the other elements. The exemplary terms "below" or "beneath" can, therefore, encompass both an orientation of above and below.

[0023] Unless otherwise defined, all terms (including technical and scientific terms) used herein have the same meaning as commonly understood by one of ordinary skill in the art to which this invention belongs. It will be further understood that terms, such as those defined in commonly used dictionaries, should be interpreted as having a meaning that is consistent with their meaning in the context of the relevant art and the present disclosure, and will not be interpreted in an idealized or overly formal sense unless expressly so defined herein.

[0024] Embodiments of the present invention are described herein with reference to cross section illustrations that are schematic illustrations of idealized embodiments of the present invention. As such, variations from the shapes of the illustrations as a result, for example, of manufacturing techniques and/or tolerances, are to be expected. Thus, embodiments of the present invention should not be construed as limited to the particular shapes of regions illustrated herein but are to include deviations in shapes that result, for example, from manufacturing. For example, a region illustrated or described as flat may, typically, have rough and/or nonlinear features. Moreover, sharp angles that are illustrated may be rounded. Thus, the regions illustrated in the figures are schematic in nature and their shapes are not intended to illustrate the precise shape of a region and are not intended to limit the scope of the present invention.

[0025] An exemplary embodiment of the present invention will hereinafter be described in detail with reference to the accompanying drawings.

[0026] FIG. 1 is an equivalent circuit diagram of an exemplary embodiment of an OLED display according to an exemplary embodiment of the present invention. The equivalent circuit diagram illustrates one pixel of such a display. FIG. 2 is a cross-sectional view of an exemplary embodiment of an organic light emitting device of the exemplary embodiment of an OLED display according to the present invention.

[0027] Referring to FIG. 1, a pixel 100 is connected to a gate signal line 10 for transferring gate signals, a data signal line 20 for transferring data signals and a driving voltage line 30 for transferring driving voltages. An organic light emitting diode ("OLED") display includes a plurality of pixels. In one

exemplary embodiment, the pixels may be arranged in a matrix formed in row and column directions. That is, the OLED display has a plurality of gate signal lines **10** extending in a row direction to run parallel to each other, a plurality of data signal lines **20** extending in a column direction to run parallel to each other, and a plurality of driving voltage lines **30**.

[0028] Each pixel **100** includes a switching transistor **40**, a driving transistor **50**, a storage capacitor **60**, and an organic light emitting diode (OLED) **200**. The switching transistor **40** has a gate electrode connected to the gate signal line **10**, a source electrode connected to the data signal line **20**, and a drain electrode connected to the driving transistor **50** and one side of the storage capacitor **60**. The switching transistor **40** transfers a data signal applied to the data signal line to the driving transistor **50** in response to a gate signal applied to the gate signal line **10**.

[0029] The driving transistor **50** has a gate electrode connected to the drain electrode of the switching transistor **40**, a source electrode connected to the driving voltage line **30** and the other side of the storage capacitor **60**, and a drain electrode connected to the OLED **200**. The driving transistor **50** outputs a current which varies with the voltage between the source electrode and the drain electrode, to the OLED **200**.

[0030] The storage capacitor **60** is placed between the gate electrode of the driving transistor **50** and the driving voltage line **30**, and stores the gate electrode signal of the driving transistor **50** when the switching transistor **40** is turned off.

[0031] According to the present exemplary embodiment, the switching and driving transistors **40** and **50** for driving the OLED **200** are n-channel field effect transistors. However, alternative configurations include embodiments in which the switching transistor **40** and/or the driving transistor **50** may be p-channel field effect transistors. Additionally, the connection relationship among the switching transistor **40**, the driving transistor **50**, the capacitor **60**, and the OLED **200** as described in accordance with the present exemplary embodiment may vary.

[0032] Referring to FIG. 2, an organic light emitting diode ("OLED") **200** includes an anode **210** connected to the drain electrode of the driving transistor **50**, a cathode **270** connected to a common voltage provided from an outside, and organic light emitting members **220** to **260** which are placed between the anode **210** and the cathode **270** and emit light by electron-hole coupling. Since the cathode **270** is provided with the common voltage, the intensity of the light emitted from the organic light emitting members **220** to **260** depends on the drain electrode current of the driving transistor **50**.

[0033] More specifically, the organic light emitting members **220** to **260** are composed of red, green, and blue organic light emitting material stacked to emit white light in accordance with an additive color model.

[0034] As shown FIG. 2, the OLED **200** has the anode **210** connected to the drain electrode of the driving transistor **50**, a hole transport layer **220** adjacent to the anode **210**, the cathode **270** for providing common electrode signals which are provided from the outside, an electron transport layer **260** adjacent to the cathode **270**, and blue, red and green emission layers **230**, **240** and **250** for emitting light by coupling holes and electrons received from the hole and electron transport layers **220** and **260** to generate excitons.

[0035] Each of the blue, red and green emission layers **230**, **240** and **250** contain different light emitting materials, and may have a different light emitting efficiency under the simi-

lar electrical conditions. For example, the light emitting efficiency of the green emission layer **250** may be greater than the light emitting efficiency of the red emission layer **240**, which in turn may be greater than the light emitting efficiency of the blue emission layer **230**.

[0036] Each of the emission layers **230**, **240** and **250** in the present exemplary embodiment overlap each other and have different surface areas. Because the efficiency of the emission layers **230**, **240** and **250** decreases, for example in the order of green, red and blue, the surface area of the emission layers **230**, **240** and **250** increases in the order of green, red, and blue. Therefore, the surface area of the green emission layer **250** is the smallest, the surface area of the blue emission layer is the largest, and the surface area of the red emission layer is somewhere in between. The area difference between the emission layers **230**, **240** and **250** may be adjusted to compensate for the efficiency difference between each layer. When the efficiency difference between two layers is small, the difference in area between the two layer is correspondingly small; when the efficiency difference between two layers is large, the difference in area between the two layers is correspondingly small.

[0037] Referring to FIGS. 3 and 4, in another exemplary embodiment of the OLED **200** according to the present invention, the surface areas of emission layers **230**, **240** and **250** become smaller as they build toward the top of the OLED. The lowest emission layer **230** is directly bordered by both of the hole and electron transport layers **220** and **260**. The light emitting efficiency of the emission layers **230**, **240** and **250** increases in an upward direction in each of the FIGS. 3 and 4. Therefore, since the lowest emission layer **230** may have a lower efficiency than upper layers **240** and **250**, the area ratio therebetween should be set up with regard to such relationship.

[0038] In FIG. 3, one end of each of the emission layers **230**, **240** and **250** is aligned with each other. In FIG. 4, a narrower emission layer is placed within the boundary of a wider emission layer, and more particularly, the centers of each of the emission layers **230**, **240** and **250** may correspond to each other.

[0039] The blue, red, and green emission layers **230**, **240** and **250** of the OLEDs illustrated in FIG. 3 and FIG. 4 may be manufactured using conventional techniques. One exemplary embodiment of which is to use shadow masks having different sized openings. That is, as the efficiency of the emission layers **230**, **240** and **250** increases in order of blue, red, and green, the shadow mask for the blue emission layer has the largest opening area, and the shadow mask for the green emission layer has the smallest opening area. The resulting pixel has a stack structure of one or more emission layers which are then overlapped with a one color filter.

[0040] The anode **210** of the OLED **200** is connected to the drain electrode of the driving transistor **50** is made of transparent conductive material such as indium tin oxide ("ITO") or indium zinc oxide ("IZO"), or a reflective metal such as aluminum (Al) or alloys thereof. The cathode **270** of the OLED **200** receives a common voltage and is made of a reflective metal such as calcium (Ca), barium (Ba), magnesium (Mg), or aluminum (Al), or a transparent conductive material such as ITO or IZO.

[0041] An exemplary embodiment of an OLED **300** illustrated in FIG. 5 has a stack structure of emission layers each having different areas.

[0042] Referring to FIG. 5, the OLED 300 has an anode 310 connected to a drain electrode of a driving transistor, a hole transport layer 320 adjacent to the anode 310, a cathode 370 for providing common electrode signals which are provided from the outside, an electron transport layer 360 adjacent to the cathode 370, and green, red and blue emission layers 330, 340 and 350 for emitting light by coupling holes and electrons received from the hole and electron transport layers 320 and 360 to generate excitons.

[0043] Each of the blue, red and green emission layers 330, 340 and 350 contain different light emitting materials, and has different light emitting efficiency under similar electrical conditions. For example, the light emitting efficiency of the emission layers 330, 340 and 350 decrease in the order of green, red and blue as described above.

[0044] Each of the emission layers 330, 340 and 350 in the present exemplary embodiment overlaps each other and has a different area. As the efficiency of the emission layers 330, 340 and 350 decreases, for example, in the order of green, red and blue, the area of the emission layers 330, 340 and 350 increases in the order of green, red and blue as opposed to the configuration described in the previous exemplary embodiment. The area difference between the emission layers 330, 340 and 350 decreases with a decrease in the efficiency difference therebetween, and increases with an increase in the efficiency difference therebetween, as described above. According to the present exemplary embodiment, the emission layers 330, 340 and 350 in FIG. 5 are stacked in the order of green, red and blue from the anode 310 to the cathode 370.

[0045] More specifically, the emission layer 330 having the highest efficiency is stacked first to be placed lowest and contact the hole transport layer 320. For example, if the efficiency of a green emission layer is highest, the green emission layer is applied first. If the efficiency of a red emission layer is next highest, the red emission layer is applied on the green emission layer, and a part of the red emission layer contacts the hole transport layer 320. Then, a blue emission layer having the lowest efficiency is applied, where the lower surface of the blue emission layer contacts the hole transport layer 320 and the upper surface contacts the electron transport layer 360. Since the blue emission layer 350 directly contacts the hole transport layer 320 and the electron transport layer 360, the blue emission layer 350 is placed in the most advantageous condition to generate excitons. As a result, since the efficiency of the blue emission layer is thereby improved through direct contact with both the electron transport layer 360 and the hole transport layer 320, it is preferable for it to have a slightly smaller area ratio than that used when all three emission layers have the same structure.

[0046] FIG. 6 shows an exemplary embodiment of a process of forming the exemplary embodiment of an OLED of FIG. 5.

[0047] Deposition regions are formed by making protrusions 490 having a predetermined height on a hole transport layer 420 formed on a substrate 410. Each of the organic emission layers 430, 440 and 450 are formed in the deposition region by depositing them at an angle. The protrusions 490 may be formed by depositing a photoresist on the entire substrate 410 after the formation of the hole transport layer 420 and by exposing and developing the photoresist. The protrusions 490 may also be formed by printing a polymer on the entire substrate 410. The height of the protrusions 490 is higher than the sum of the thickness of the emission layers 430, 440 and 450.

[0048] The first emission layer 430 having the highest light emitting efficiency is first deposited at an angle of α on the substrate 410 on which the protrusions 490 are formed, wherein α is in range of about 0 degrees to about 90 degrees with respect to the horizontal surface of the substrate 410. Accordingly, the first emission layer 430 having an area "a" is formed between two adjacent protrusions 490 on the hole transport layer 420. Next, the second emission layer 440 having the second best light emitting efficiency is deposited at an angle of β , wherein β is in range of about 0 degrees to about 90 degrees with respect to the horizontal surface of the substrate 410. Herein, β is larger than α . The second emission layer 440 having an area "b" is formed between two adjacent protrusions 490 while contacting the first emission layer 430 and the hole transport layer 420. Lastly, the third emission layer 450 having the lowest efficiency is deposited in a direction substantially perpendicular to the substrate 410. Accordingly, the third emission layer 450 having an area "c" is formed between two adjacent protrusions 490 while contacting the second emission layer 440 and the hole transport layer 420.

[0049] According to one exemplary embodiment, the first, second and third emission layers 430, 440 and 450 are deposited using shadow masks in which only regions corresponding to the emission layers 430, 440 and 450 are open to prevent the light emitting material from being deposited on the other regions. Next, the electron transport layer (not shown) and the cathode (not shown) are sequentially stacked on the upper surface of the third emission layer 450 to complete the OLED.

[0050] If the height of the protrusions 490 is too much higher than the entire height of the emission layers 430, 440 and 450, the electron transport layer and the cathode may be overstretched, thereby causing gaps in either of the layers which leads to short-circuits. Therefore, in one exemplary embodiment the height of the protrusions 490 is set to within twice the cumulative height of the emission layers 430, 440 and 450. In another exemplary embodiment, since the third emission layer 450 is deposited perpendicularly to the substrate 410 the deposition angles for depositing the first and second emission layers 430 and 440 may be maintained within the range of about 45 degrees to about 90 degrees with respect to the horizontal surface of the substrate 410. According to this exemplary embodiment of a method of manufacturing an exemplary embodiment of an OLED display it is possible to form a plurality of emission layer deposition regions in one pixel in order to generate white light to be turned into one color by a color filter.

[0051] An exemplary embodiment of an OLED display according to the present invention includes a pixel having a cross-section illustrated in FIG. 7. In the exemplary embodiment of a pixel of the exemplary embodiment of an OLED display shown in FIG. 7, first and second gate electrodes 520a and 520b and a gate line (not shown, referring to the gate signal line of FIG. 1) are formed on an insulation substrate 510. In one exemplary embodiment the insulation substrate 510 may be made of a transparent glass or plastic material. The gate line for transferring gate signals is formed in a horizontal direction and includes a pad region 520c having a wide area to receive signals from the outside. The first gate electrode 520a is connected to the gate line and extends upward, and the second gate electrode 520b is formed separately from the gate line. A gate driving circuit (not shown) is directly mounted on the substrate 510 or on another external

device to be connected to the gate pad **520c**. Alternative exemplary embodiments include the configuration where the gate driving circuit is directly connected to the gate line without necessitating a gate pad region **520c**.

[0052] In one exemplary embodiment the first gate electrode **520a**, the second gate electrode **520b** and the gate line may be formed of a single layer made of aluminum, silver, copper, molybdenum, chromium, tantalum, titanium, a metal of the same group thereof, or alloys thereof. Alternative exemplary embodiments include configurations where the gate electrodes and lines comprise a multi-layer structure stacked with different kinds of metals. The multi-layer structure may be made of a combination of ITO and a low resistance material for reducing signal delay or voltage drop, or IZO and a material having physically, chemically, and electrically excellent contact characteristics. The low resistance material may be a metal such as aluminum, silver, or copper, or alloys thereof. Exemplary embodiments of the material with excellent contact characteristics may be molybdenum, chromium, titanium, or tantalum. The first gate electrode **520a**, the second gate electrode **520b**, and the gate line are formed at an angle of about 30 degrees to about 80 degrees with respect to the substrate **510**.

[0053] The first gate electrode **520a**, the second gate electrode **520b**, and the gate line are covered with a gate insulating layer **525**. In one exemplary embodiment, the gate insulating layer **525** may be made of silicon nitride ("SiN_x") or silicon oxide ("SiO_x"). A semiconductor stripe **530a** or a semiconductor island **530b** is formed on the top of the gate insulating layer **525**. In one exemplary embodiment, the semiconductor stripe **530a** or semiconductor island **530b** may be made from hydrogenated amorphous silicon or polysilicon. The semiconductor stripe **530a** extends in a mainly vertical direction to the gate line, and includes a plurality of projections (not shown) extending to the first gate electrode **520a**. The semiconductor island **530b** is placed on the second gate electrode **520b**.

[0054] A plurality of first and second ohmic contacts **535a** and **535b** are formed on the semiconductor stripe **530a** and the semiconductor island **530b**, respectively. In one exemplary embodiment, the ohmic contacts may be made of a material such as n+ hydrogenated amorphous silicon, which is highly doped with an n-type impurity such as phosphorous (P), or silicide.

[0055] A data line (not shown, referring to the data signal line of FIG. 1), a driving voltage line (referring to FIG. 1), and data conductors **545a** and **545b** are formed on the ohmic contacts **535a** and **535b** and the gate insulating layer **525**. The data conductors **545a** and **545b** comprise the source and drain electrodes of a switching transistor and source and drain electrodes of a driving transistor.

[0056] The data line for transferring data signals extends vertically and intersects with the gate line. The data line (not shown) includes the first source electrode formed in the direction of the gate electrode **520a** and a wide pad region **540** to receive signals from the outside. Herein, a data driving circuit (not shown) may be mounted on the substrate **510** or on another external device to be connected to the data pad **540**.

[0057] The driving voltage line for transferring driving voltages extends vertically and intersects with the gate line. The driving voltage line includes a wide pad region (not shown) to receive signals from the outside. Alternative exemplary embodiments include the configuration where the data

driving circuit is directly connected to the data line without necessitating a data pad region **540**.

[0058] In one exemplary embodiment the data line, driving voltage line, and data conductors **545a** and **545b** are made of a refractory metal such as molybdenum, chromium, tantalum, and titanium, or alloys thereof. In another exemplary embodiment, the data line, driving voltage line, and data conductors **545a** and **545b** may have a multi-layer structure including a refractory metal film (not shown) and a low resistance conductive film (not shown). An exemplary embodiment of the multi-layer structure may be a double layer consisting of a lower layer such as chromium or molybdenum (or alloys thereof) and an upper layer such as aluminum (or an alloy thereof), or a triple layer consisting of a lower layer such as molybdenum (or an alloy thereof), a middle layer such as aluminum (or an alloy thereof), and an upper layer such as molybdenum (or an alloy thereof). The data line, the driving voltage line, and the data conductors **545a** and **545b** are formed so that they have sides which form an angle of about 30 degrees to about 80 degrees with respect to the substrate **510**.

[0059] The driving transistor includes the data conductors **545b**, the second ohmic contacts **535b**, the semiconductor island **530b**, the gate insulating layer **525**, and the second gate electrode **520b**. The switching transistor includes the data conductors **545a**, the first ohmic contacts **535a**, the semiconductor stripe **530a**, the gate insulating layer **525**, and the first gate electrode **520a**.

[0060] A color filter layer **550** is formed on the gate insulating layer **525** and is placed under the region on which the OLED will be formed. A color filter layer **550** is formed on each pixel and passes the light output from the OLED there-through to emit a predetermined color. The color filter layer **550** may be blue, green or red although only one color is applied to each individual pixel. Although the color filter layer **550** is placed under the OLED in the present exemplary embodiment, the color filter layer **550** may be placed on the top of the OLED or anywhere else under the OLED as long as it passes light to emit the predetermined color. The exemplary embodiment described above describes a bottom-type of display where light is emitted to an outside through the bottom of the substrate **510**. However, alternative exemplary embodiments of the OLED display also include top-type displays where light is emitted through the top of a common electrode **770** (to be described below) to an outside.

[0061] A passivation layer **560** is formed on the data conductors **545a** and **545b**, the exposed semiconductors **530a** and **530b**, the gate insulating layer **525**, the exposed sides of the first and second ohmic contacts **535a** and **535b** and the color filter layer **550**. The passivation layer **560** is made of an inorganic insulator or an organic insulator and has a flat surface. In one exemplary embodiment the inorganic insulator may be silicon nitride or silicon oxide, it may be photosensitive and it may have a dielectric constant of less than about 4.0. Alternative exemplary embodiments include the configuration where the passivation layer may have a double layer structure consisting of a lower inorganic layer and an upper organic layer in order to protect the insulating characteristic of the organic layer, and the exposed semiconductors **535a** and **535b**.

[0062] The passivation layer **560** has a plurality of contact holes **565a**, **565b**, **565c**, **565d** and **565e** to expose a part of the second gate electrode **520b**, the pad region of the gate line **520c**, the pad region of the data line **540**, and the data con-

ductors **545a** and **545b**. A plurality of pixel electrodes **600**, a plurality of connecting members **610**, and a plurality of contact assistants **620** and **630** are formed on the passivation layer **560**. In one exemplary embodiment the pixel electrodes **600**, the connecting members **610** and contact assistants **620** and **630** are made of a transparent conductive material such as ITO or IZO, or a reflective metal such as aluminum, silver, or alloys thereof.

[0063] The pixel electrode **600** is connected to the drain electrode of the driving transistor through the contact hole **565c**. The connecting member **610** connects the drain electrode of the switching transistor and the gate electrode of the driving transistor through the contact holes **565a** and **565b**.

[0064] A barrier **700** is formed on the passivation layer **560** to surround edges of pixel electrode **600** and define a space in which the OLED **200** is formed. The barrier **700** is composed of an organic or inorganic material.

[0065] A common electrode **770** is disposed on the OLED **200** and the barrier to complete the display. Exemplary embodiments of the common electrode **770** may be formed from the same material as the pixel electrode **600**, the data conductors **545a** and **545b** or the gate electrodes.

[0066] As described above, the organic light emitting unit has layers of a red, blue and green light emitting material, each having a different surface area. The OLED emits high purity white light so that when passed through the color filters of each individual pixel of a plurality of pixels the OLED display can realize full color.

[0067] While the present invention has been described in connection with what is presently considered to be practical exemplary embodiments, it is to be understood that the present invention is not limited to the disclosed exemplary embodiments, but, on the contrary, is intended to cover various modifications and equivalent arrangements included within the spirit and scope of the appended claims.

What is claimed is:

1. An organic light emitting diode display comprising:
 - a first electrode;
 - a second electrode;
 - a plurality of organic emission layers disposed between the first electrode and the second electrode; and
 - a color filter layer which passes the light emitted from the plurality of organic emission layers,
 - wherein the plurality of organic emission layers are sequentially stacked and each have a different surface area.
2. The organic light emitting diode display of claim 1, wherein each of the organic emission layers emits one of red, green and blue light.
3. The organic light emitting diode display of claim 2, wherein the organic emission layers include red, green and blue emission layers, and

wherein the blue emission layer has a wider area than those of the red and green emission layers.

4. The organic light emitting diode of claim 2, wherein the organic emission layers include a first emission layer adjacent to the first electrode, and second and third emission layers separated from the first electrode, and

wherein the first emission layer has a wider area than those of the second and third emission layers.

5. The organic light emitting diode display of claim 2, wherein the organic emission layers include a first emission layer adjacent to the second electrode, and second and third emission layers separated from the second electrode, and

wherein the first emission layer has a wider area than those of the second and third emission layers.

6. The organic light emitting diode display of claim 2, wherein at least one edge of each of the plurality of organic emission layers is aligned with each other,

wherein the edge is defined as the side of the organic emission layer which is perpendicular to the plane of the substrate on which the layer is formed.

7. The organic light emitting diode display of claim 2, wherein a center of each of the plurality of organic emission layers is aligned with each other.

8. The organic light emitting diode display of claim 2, wherein the color filter layer is overlapped with the plurality of organic emission layers.

9. An organic light emitting diode display comprising:

- a gate electrode which provides gate signals;
- a data electrode which provides data signals;
- a power source electrode which provides power source signals;

a switching transistor and a driving transistor operated in response to signals provided from the gate electrode, the data electrode, and the power source electrode;

a first electrode electrically connected to the driving transistor;

a second electrode disposed opposite the first electrode; first, second and third emission layers disposed between the first electrode and the second electrode to be overlapped with each other; and

a color filter overlapped with the first, second and third emission layers,

wherein the first, second and third emission layers each have different emission surface areas.

10. The organic light emitting diode display of claim 9, wherein the first, second and third emission layers are formed by deposition using a plurality of shadow masks each having different opening areas.

* * * * *

专利名称(译)	有机发光二极管显示器		
公开(公告)号	US20100295828A1	公开(公告)日	2010-11-25
申请号	US12/848465	申请日	2010-08-02
[标]申请(专利权)人(译)	三星电子株式会社		
申请(专利权)人(译)	三星电子有限公司		
当前申请(专利权)人(译)	三星DISPLAY CO., LTD.		
[标]发明人	SUNG UN CHEOL LEE JOO HYEON		
发明人	SUNG, UN-CHEOL LEE, JOO-HYEON		
IPC分类号	G09G3/32 G09G5/00 H01L51/52		
CPC分类号	H01L27/322 H01L27/3246 H05B33/14 H01L51/56 H01L51/5036		
优先权	1020050110712 2005-11-18 KR		
其他公开文献	US8125142		
外部链接	Espacenet USPTO		

摘要(译)

用于提高白光发光效率和简化制造工艺的OLED显示器包括多个像素，每个像素具有晶体管单元，滤色器单元和有机发光器件单元。晶体管单元将来自外部的信号转换为驱动信号，以驱动有机发光器件单元。有机发光器件单元由蓝色，红色和绿色发光层组成，每个发光层具有不同的面积。通过使白光通过彩色滤光片，OLED显示器可以实现全彩色。

